



MACEDONIA CONDOS



3 Bedroom Units

This Easterly facing building boasts views on the Par 3, 9th hole and the Silo Ridge equestrian building across the valley. The 3-bedroom units range from 3,261 to 3,372 square feet. Each unit has generous outdoor terrace space including a cozy outdoor fireplace. Parking is provided street-side on the main entry level or in the parking garage on the basement level with elevator access directly into each individual unit.

FLOOR PLAN

Unit 1

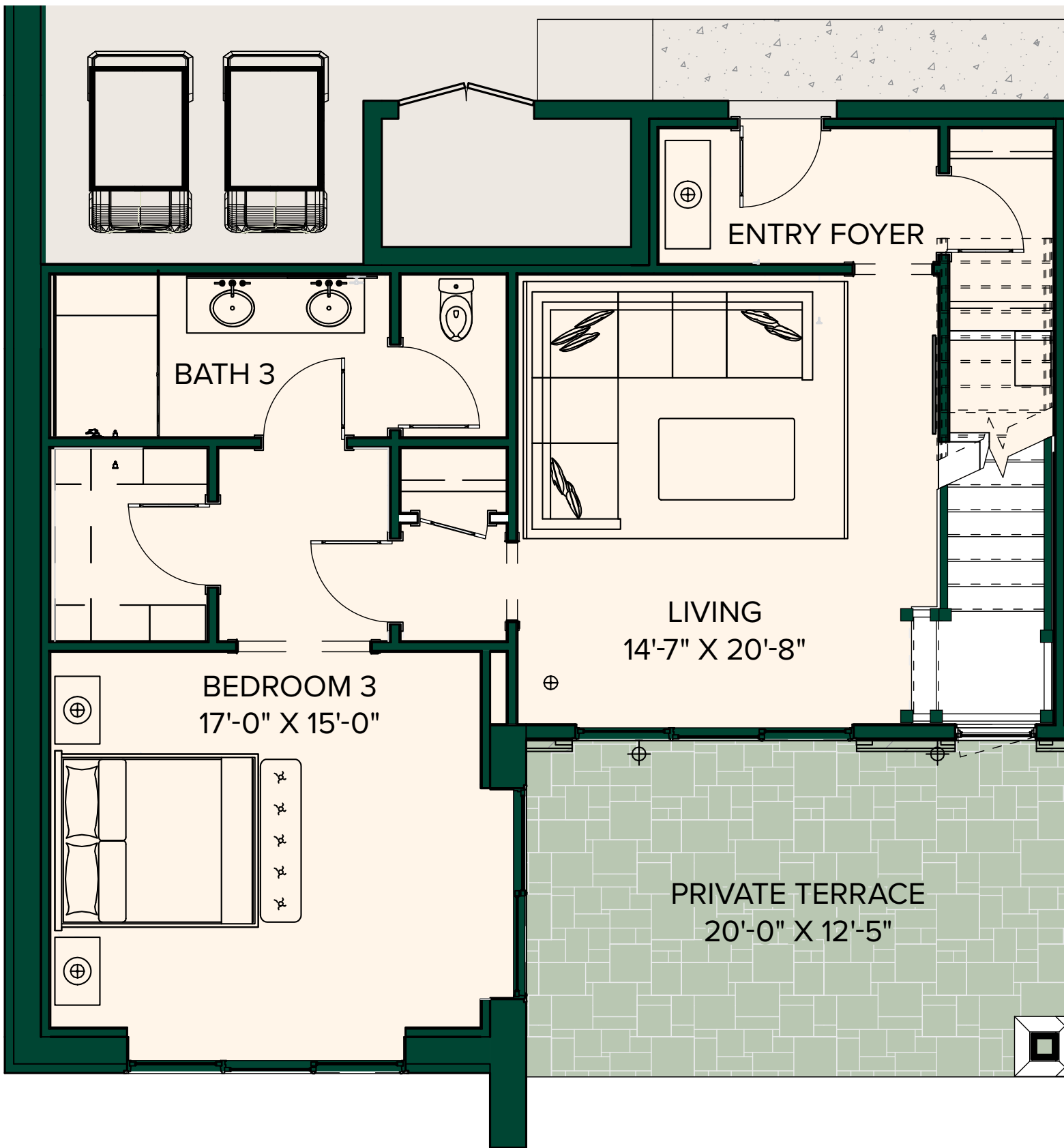

LOWER LEVEL

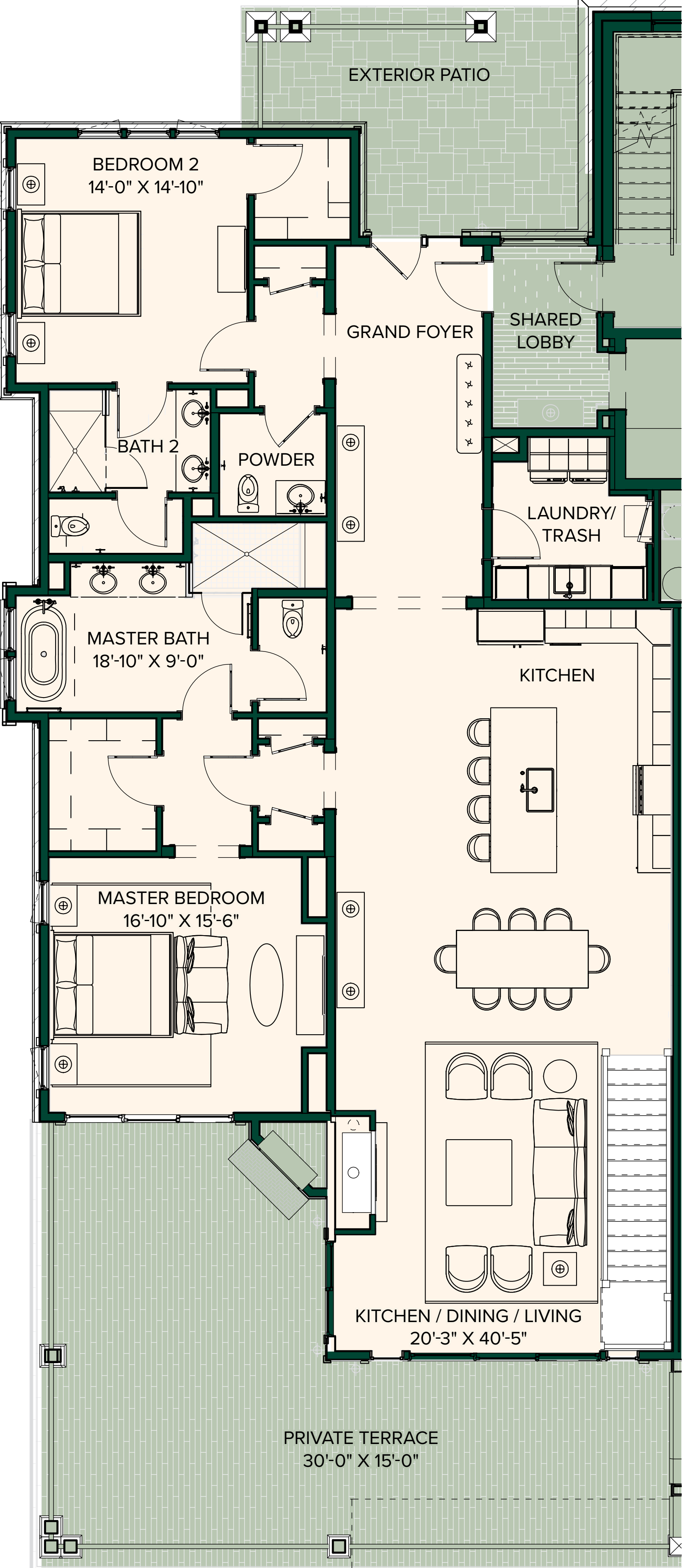

UPPER LEVEL

UNIT AREA

FLOOR	LEVEL	AREA
1	Lower	883 SF
2	Upper	2,489 SF
Total		3,372 SF

MACEDONIA CONDOS

FIRST FLOOR

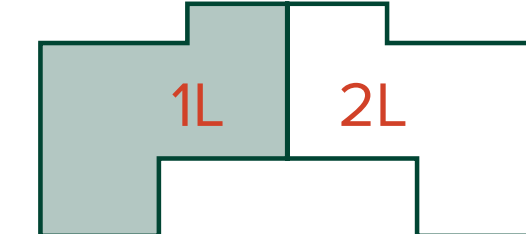

SECOND FLOOR

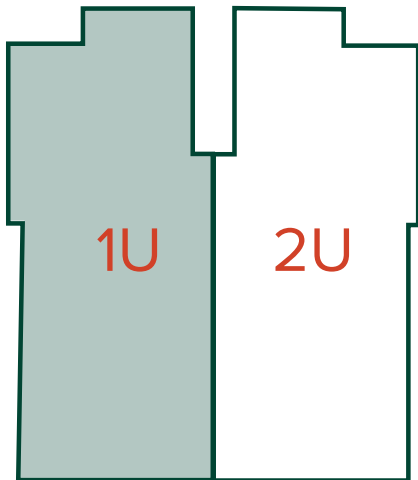

THIRD FLOOR

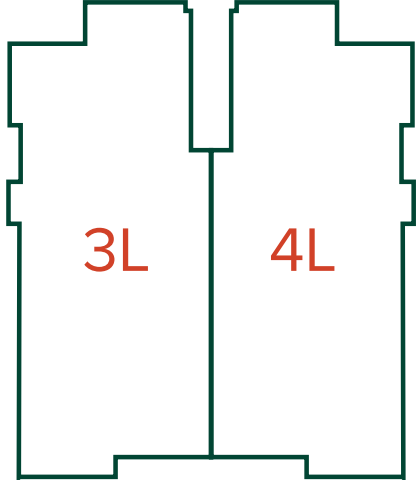

FOURTH FLOOR

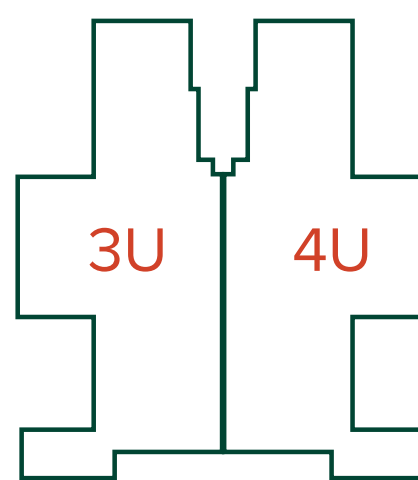

FLOOR PLAN

Unit 2

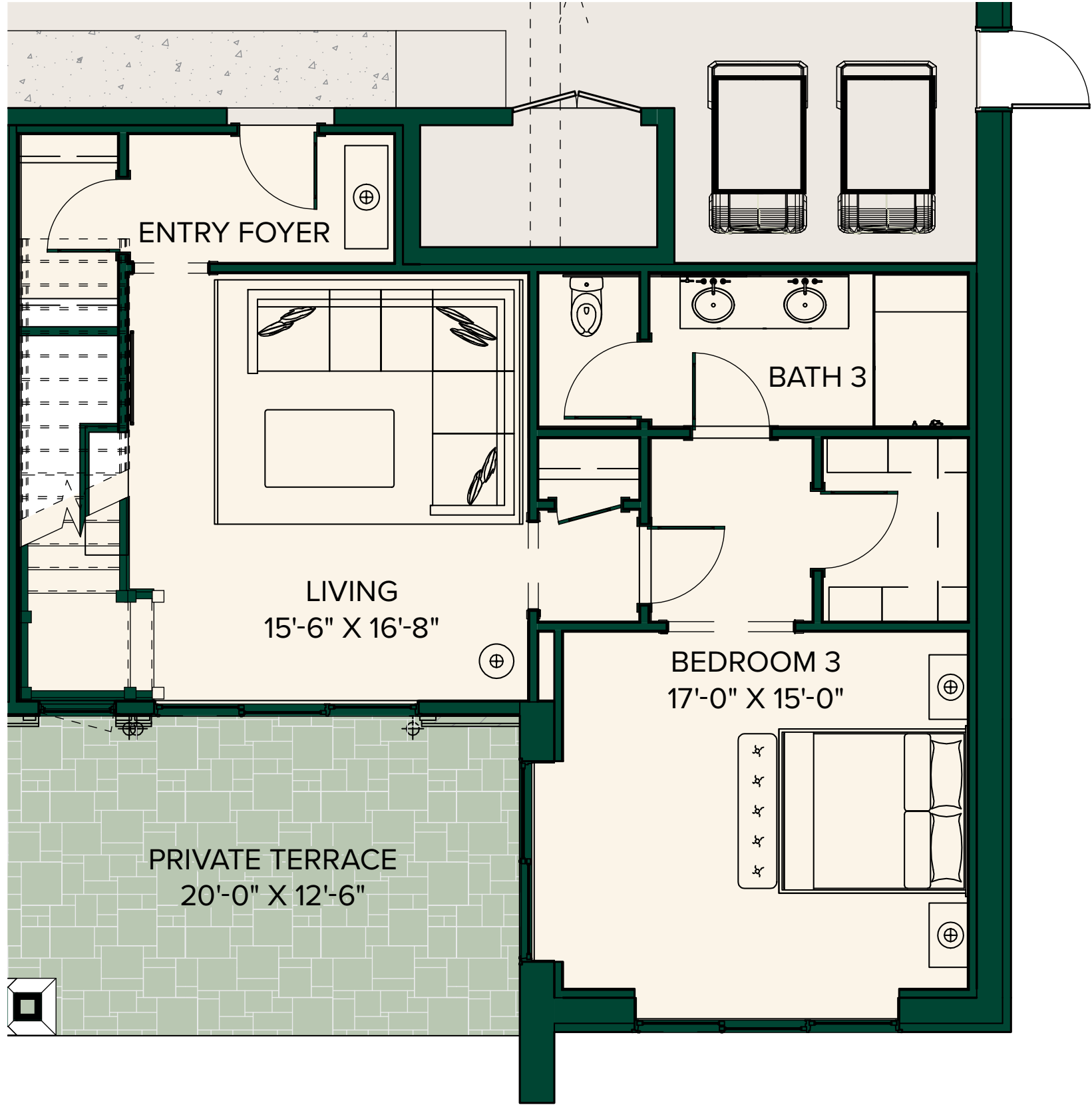

LOWER LEVEL

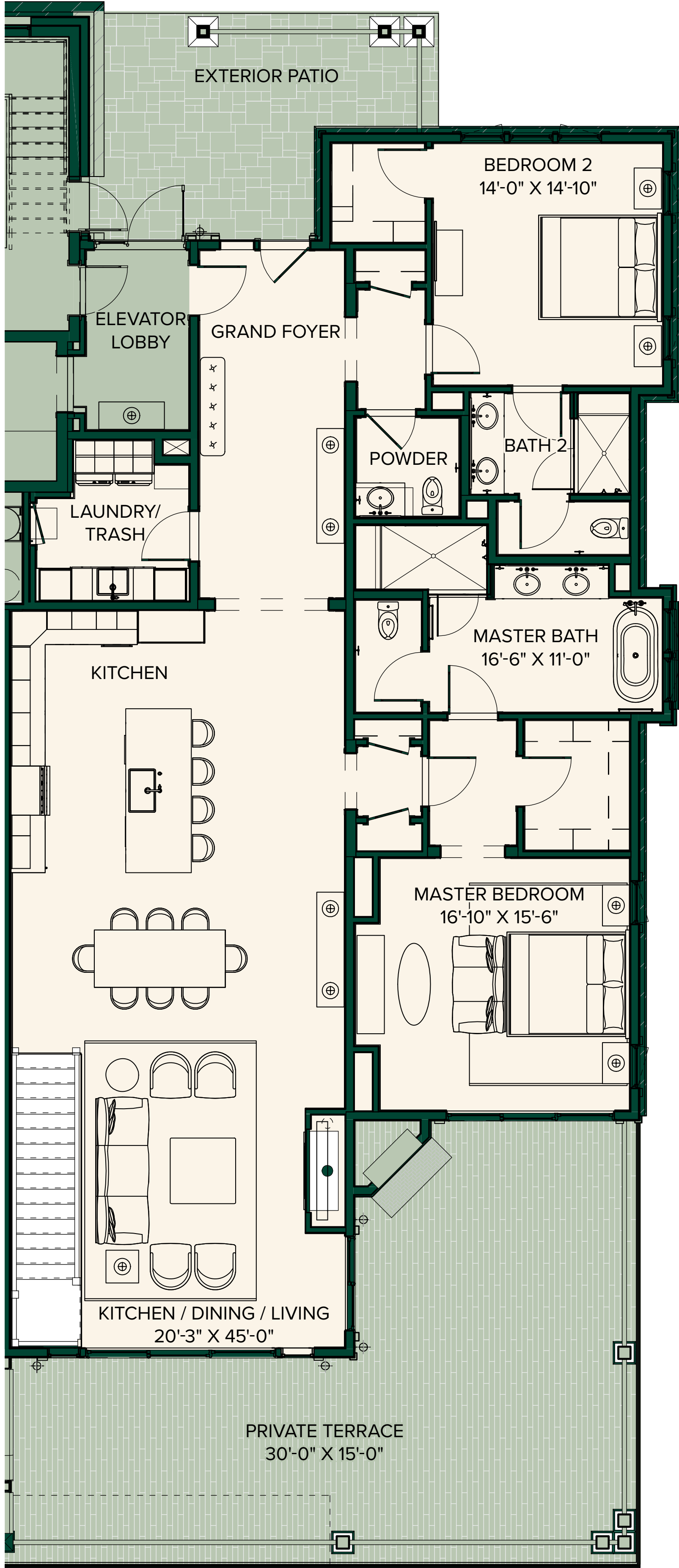

UPPER LEVEL

UNIT AREA

FLOOR	LEVEL	AREA
1	Lower	883 SF
2	Upper	2,489 SF
Total		3,372 SF

MACEDONIA CONDOS

FIRST FLOOR

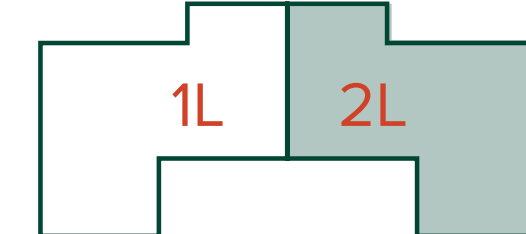

SECOND FLOOR

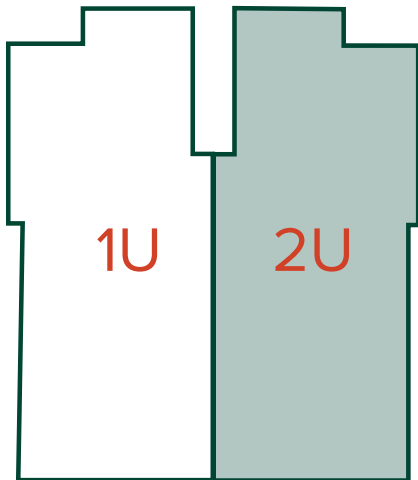

THIRD FLOOR

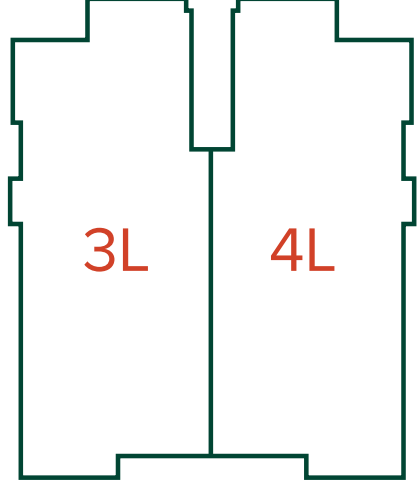

FOURTH FLOOR

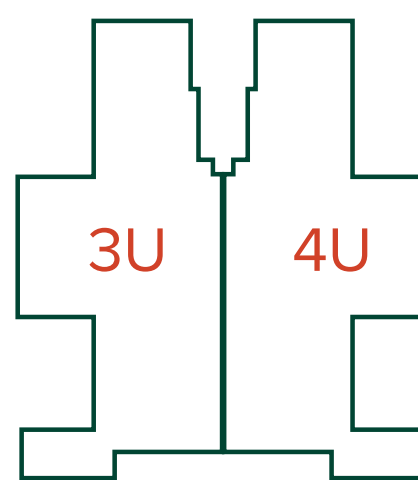

FLOOR PLAN

Unit 3

LOWER LEVEL

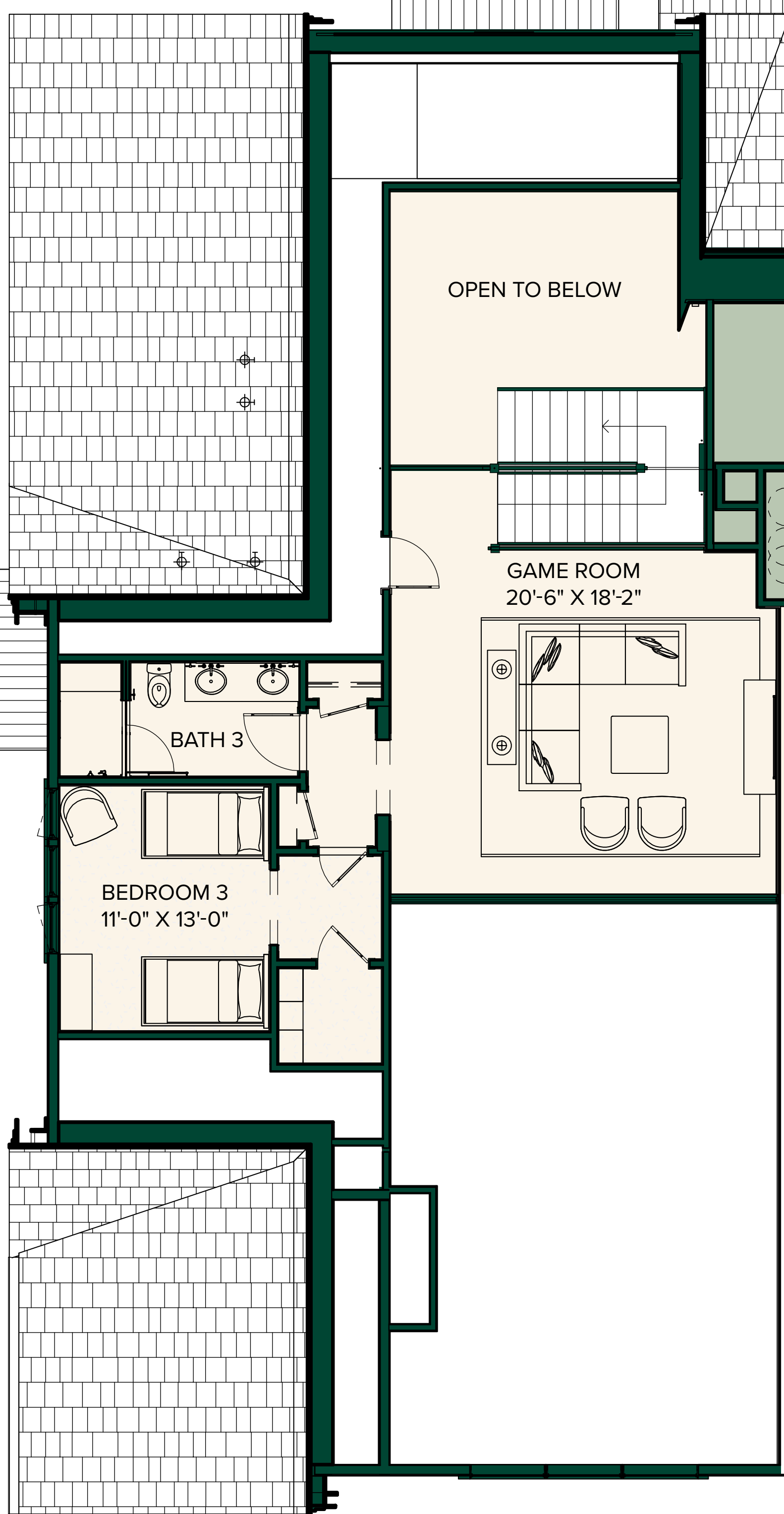
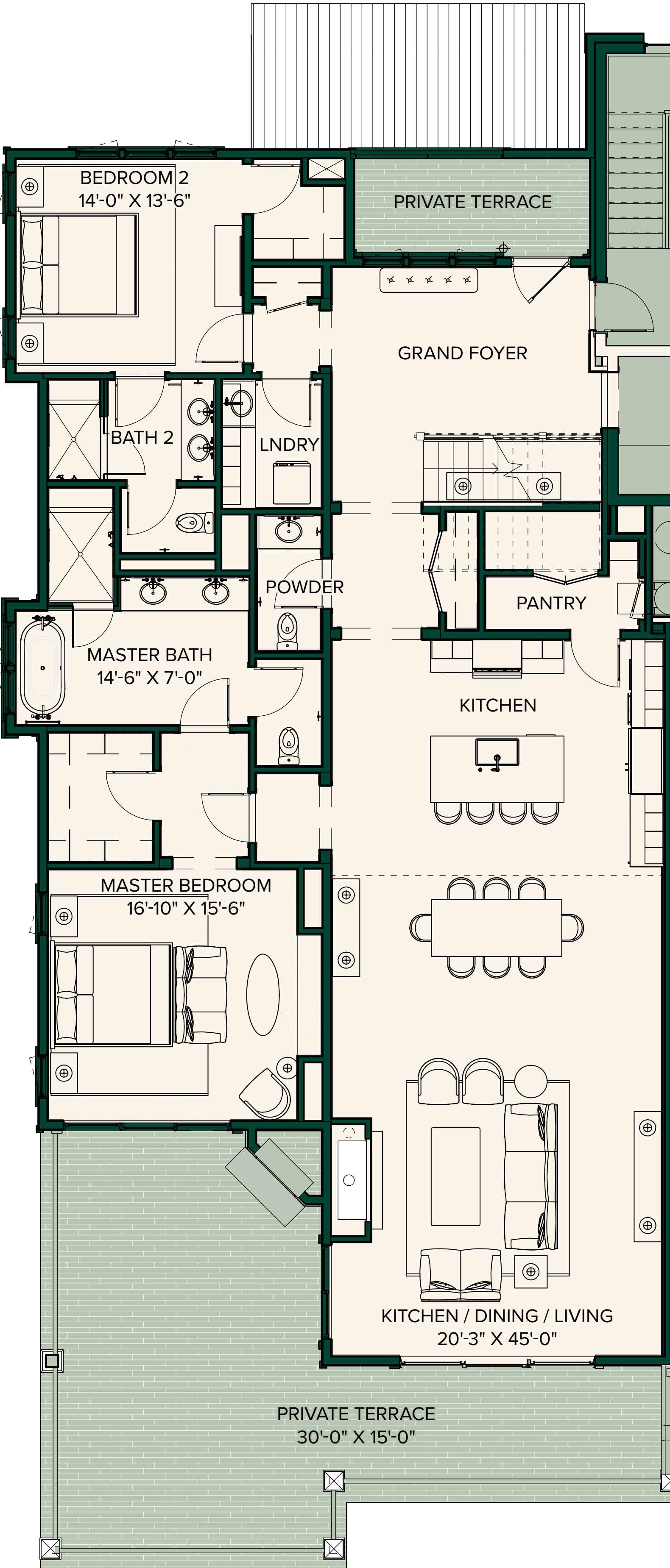

UPPER LEVEL

UNIT AREA

FLOOR	LEVEL	AREA
2	Lower	2,488 SF
3	Upper	773 SF
Total		3,261 SF

MACEDONIA CONDOS

FIRST FLOOR

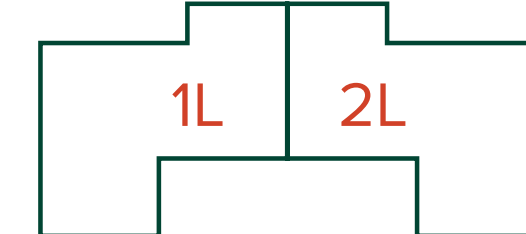

SECOND FLOOR

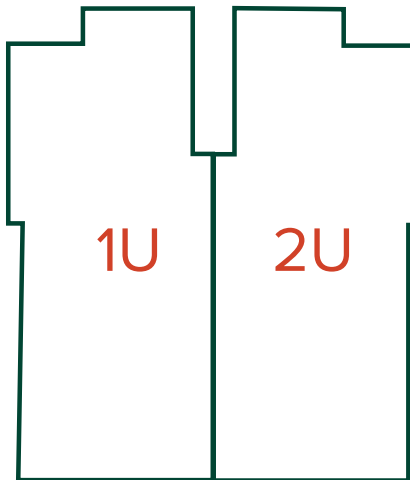

THIRD FLOOR

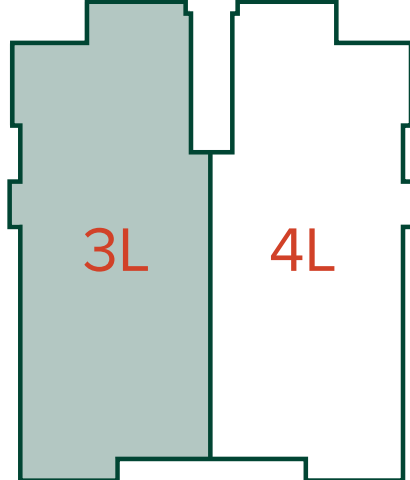

FOURTH FLOOR

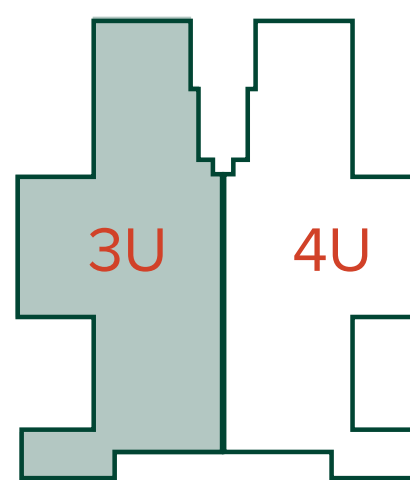

FLOOR PLAN

Unit 4

LOWER LEVEL

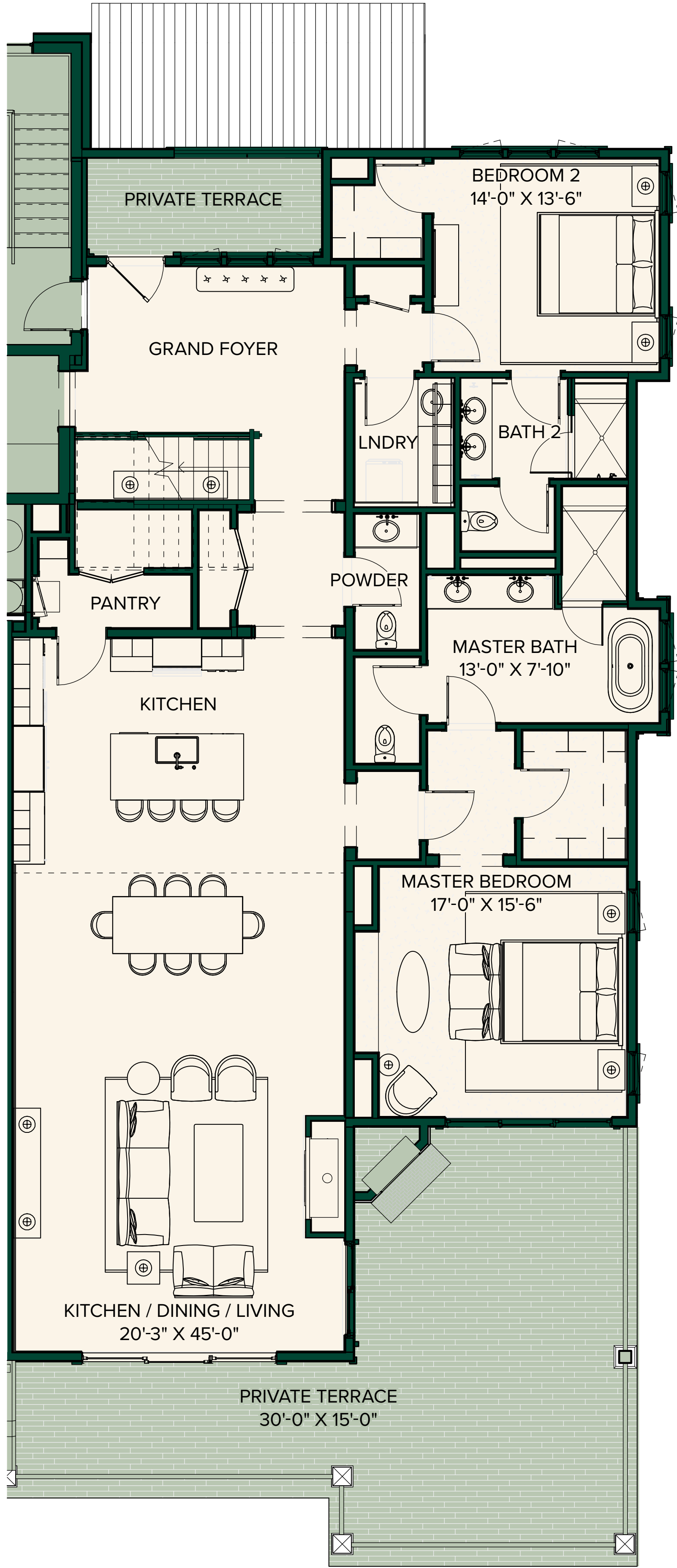

UPPER LEVEL

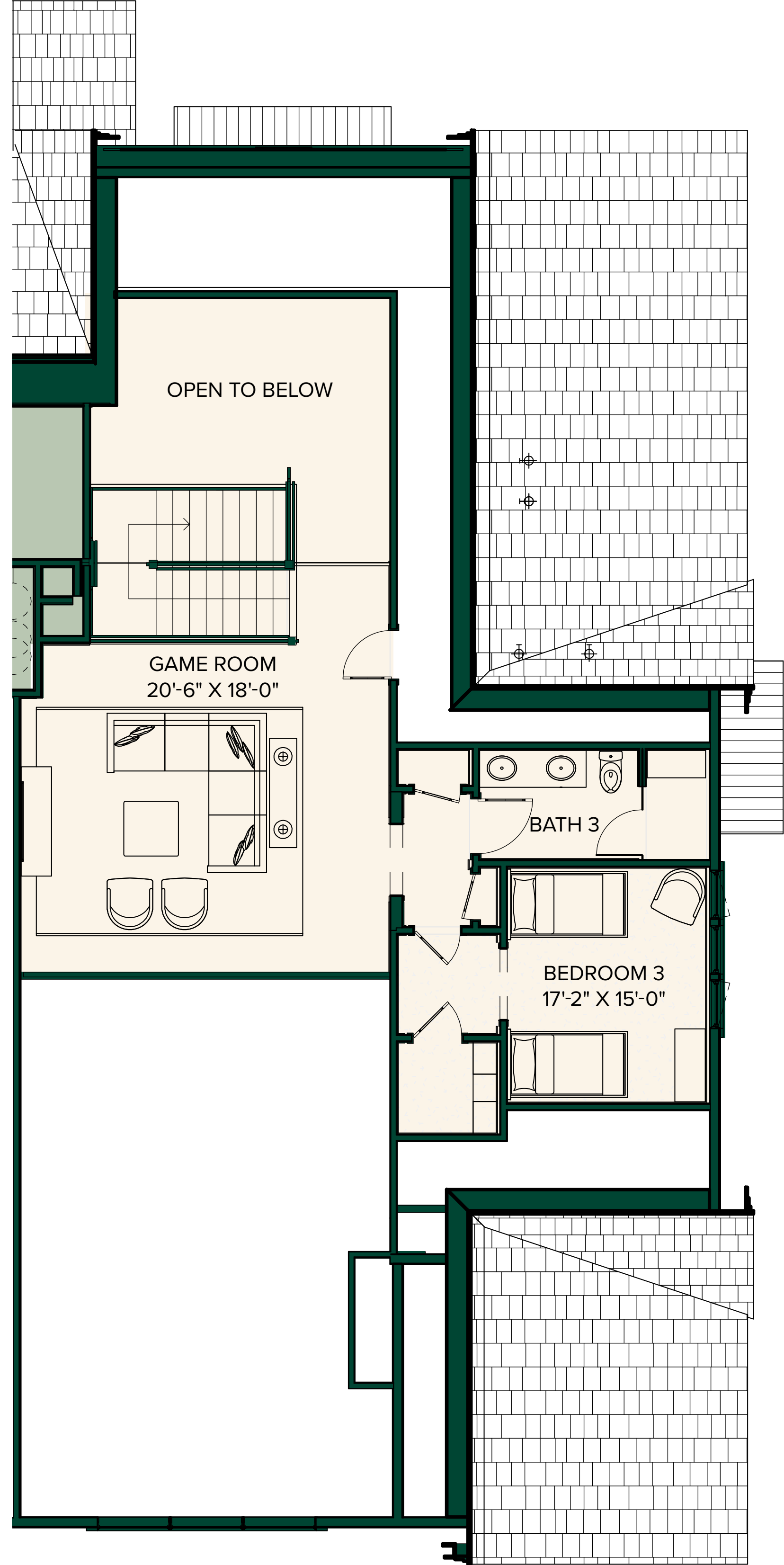

UNIT AREA

FLOOR	LEVEL	AREA
2	Lower	2,488 SF
3	Upper	773 SF
Total		3,261 SF

MACEDONIA CONDOS

FIRST FLOOR

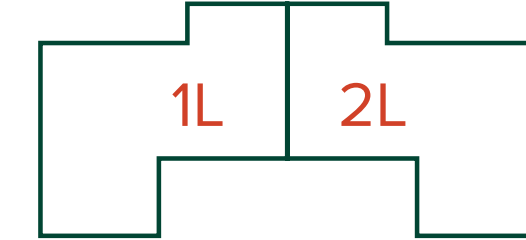

SECOND FLOOR

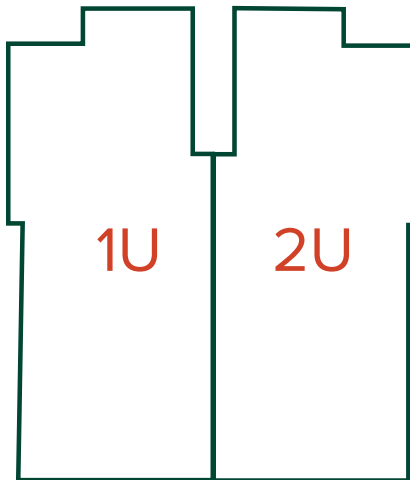

THIRD FLOOR

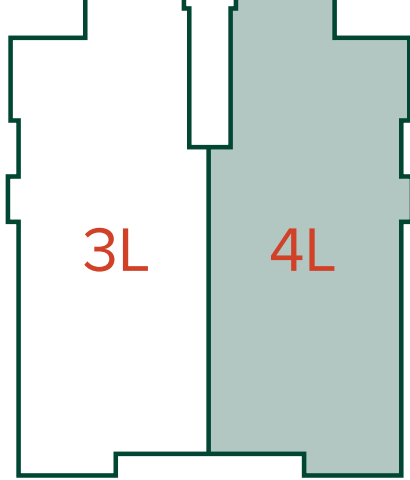

FOURTH FLOOR

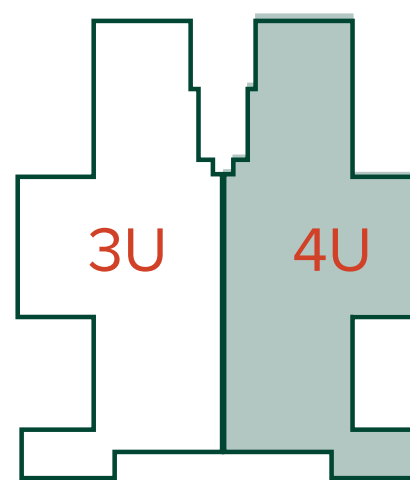



T 845.789.1770

E sales@siloridge.com

SILO RIDGE FIELD CLUB

5021 Route 44, Amenia, NY 12501

These materials and the features and amenities described and depicted herein are based upon current development plans, which are subject to change without notice. Obtain the property report required by applicable government authorities before signing anything. No governmental agency has judged the merits or value, if any, of this property. This material shall not constitute an offer to sell in any state where prior registration is required.